

**Modular Cooking Range Line
 thermaline 80 - 4 Zone Electric Solid
 Top on Oven, 1 Side, Ecotop with
 Backsplash, H=800**

ITEM # _____

MODEL # _____

NAME # _____

SIS # _____

AIA # _____

588421 (MALMFBH8AO)

 Electric Solid Top, 4 zones,
 ecoTop coating, one-side
 operated with backsplash,
 on Oven

Short Form Specification

Item No.

Unit constructed according to DIN 18860_2 with 20 mm drop nose top and 70 mm recessed plinth. Internal frame for heavy duty sturdiness in stainless steel. 2 mm top in 1.4301 (AISI 304). Flat surface construction, easily cleanable. THERMODUL connection system enables seamless worktop when units are connected and avoids soil penetrating. ECOTOP model with a 20 mm thick steel cooking surface with heat retaining coating. 4 independently controlled heating zones with 2 electronic sensors per zone for temperature surface control and 8 power levels. Rapid plate heat up, continuously ready to use. Overheat protection switches off the supply in case of overheating. Standby function saves energy and quickly recovers maximum power. Metal knobs with embedded hygienic silicon "soft" grip enable easier handling and cleaning. Electric static oven base with 40 mm thick oven door and ribbed enamelled steel base plate. Constructed according to 1.4301 (AISI 304). Oven chamber with 2 levels of runners for 2/1 GN shelves to enable simultaneous and faster cooking. Heavy duty thermostat with temperature range up to 300°C, electronic sensor for precise temperature control and manual humidity control in the cooking chamber. Upper heating element can also be used for grilling, with or without ventilating mode. Flat surface construction, easily cleanable. Overheat protection switches off the supply in case of overheating. Standby function saves energy and quickly recovers maximum power. Metal knobs and oven handles ergonomically designed with embedded hygienic silicon "soft" grip enable easier handling and cleaning. IPX5 water resistance certification.

Main Features

- 4 heating zones independently controlled.
 - Rapid heat up of the plate and continuously ready for use.
 - Overheat protection: the temperature sensor switches off the supply in case of overheating.
 - Pans can easily be moved from one area to another without lifting.
 - Wide rounded cleaning zone around the plates for easier cleaning.
 - All major components may be easily accessed from the front.
 - THERMODUL connection system creates a seamless work top when units are connected to each other thus avoiding soil penetrating vital components and facilitating the removal of units in case of replacement or service.
 - Metal knobs with embedded hygienic "soft-touch" grip for easier handling and cleaning. The special design of the controls prevents infiltration of liquids or soil into vital components.
 - Cooking plate and base joint profile guarantee against soil infiltration.
 - Two electronic sensors per zone to control surface temperature and to protect cooking plate from overheating.
 - 8 power levels.
 - Large visible digital display manufactured in tempered glass to resist heat and chemicals, showing temperatures or power settings. The display also shows on/off status of the appliance and on/off status of the heating elements.
 - 40 mm thick oven door for heat insulation.
 - Handles are ergonomically designed with silicon "soft" grip for easy handling and cleaning.
 - Oven chamber to have 2 levels of runners to accommodate 2/1 GN trays and ribbed enamelled steel base plate.
 - Heavy duty thermostat with temperature range up to 300°C.
 - The upper heating element of the oven can also be used for grilling.
 - Manual control of humidity in cooking chamber.
 - Electronic sensor for precise temperature control.
 - Unit constructed according to DIN 18860_2 with 70 mm recessed plinth.
 - Oven temperature up to 300 °C
 - ECOTOP model has a 20 mm thick steel DIN 1.7335 nickel coated cooking surface.
- ### Construction
- 2 mm top in 1.4301 (AISI 304).
 - Flat surface construction with minimal hidden areas to easily clean all surfaces
 - Unit constructed according to DIN 18860_2 with 20 mm drop nose top.
 - Unit constructed according to DIN 18860_2 with 20 mm drop nose top and 70 mm recessed plinth.
 - IPX5 water resistance certification.

APPROVAL: _____

- Internal frame for heavy duty sturdiness in stainless steel.

Sustainability



- Standby function for energy saving and fast recovery of maximum power.

Included Accessories

- 1 of Grid, chromium plated, for ovens PNC 910652
2/1 GN

Optional Accessories

- | | | |
|--|------------|--------------------------|
| • Baking sheet 2/1 GN for ovens | PNC 910651 | <input type="checkbox"/> |
| • Bottom steel plate 2/1 GN for fire
clay plate 800&900 with baking
oven | PNC 910655 | <input type="checkbox"/> |
| • Fire clay plate 2/1 GN for ovens | PNC 910656 | <input type="checkbox"/> |
| • Connecting rail kit for appliances
with backsplash, 800mm | PNC 912497 | <input type="checkbox"/> |
| • Portioning shelf, 800mm width | PNC 912526 | <input type="checkbox"/> |
| • Portioning shelf, 800mm width | PNC 912556 | <input type="checkbox"/> |
| • Folding shelf, 300x800mm | PNC 912577 | <input type="checkbox"/> |
| • Folding shelf, 400x800mm | PNC 912578 | <input type="checkbox"/> |
| • Fixed side shelf, 200x800mm | PNC 912583 | <input type="checkbox"/> |
| • Fixed side shelf, 300x800mm | PNC 912584 | <input type="checkbox"/> |
| • Fixed side shelf, 400x800mm | PNC 912585 | <input type="checkbox"/> |
| • Stainless steel front kicking strip,
800mm width | PNC 912598 | <input type="checkbox"/> |
| • Stainless steel side kicking strips left
and right, against the wall, 800mm
width | PNC 912622 | <input type="checkbox"/> |
| • Stainless steel side kicking strips left
and right, back-to-back, 1610mm
width | PNC 912625 | <input type="checkbox"/> |
| • Stainless steel plinth, against wall,
800mm width | PNC 912806 | <input type="checkbox"/> |
| • Connecting rail kit for appliances
with backsplash: modular 80 (on the
left), ProThermetic tilting (on the
right), ProThermetic stationary (on
the left) to ProThermetic tilting (on
the right) | PNC 912977 | <input type="checkbox"/> |
| • Connecting rail kit for appliances
with backsplash: modular 80 (on the
right), ProThermetic tilting (on the
left), ProThermetic stationary (on the
right) to ProThermetic tilting (on the
left) | PNC 912978 | <input type="checkbox"/> |
| • Back panel, 800x800mm, for units
with backsplash | PNC 913026 | <input type="checkbox"/> |
| • Stainless steel panel, 800x800mm,
against wall, left side | PNC 913094 | <input type="checkbox"/> |
| • Stainless steel panel, 800x800mm,
flush-fitting, against wall, right side | PNC 913098 | <input type="checkbox"/> |
| • Endrail kit, flush-fitting, with
backsplash, left | PNC 913113 | <input type="checkbox"/> |
| • Endrail kit, flush-fitting, with
backsplash, right | PNC 913114 | <input type="checkbox"/> |
| • Endrail kit (12.5mm) for thermaline 80
units with backsplash, left | PNC 913204 | <input type="checkbox"/> |
| • Endrail kit (12.5mm) for thermaline 80
units with backsplash, right | PNC 913205 | <input type="checkbox"/> |
| • U-clamping rail for back-to-back
installations with backsplash (to be
ordered as S-code) | PNC 913226 | <input type="checkbox"/> |
| • Insert profile D=800mm | PNC 913230 | <input type="checkbox"/> |

- Energy optimizer kit 32A - factory fitted PNC 913247
- Side reinforced panel only in combination with side shelf for against the wall installations, left PNC 913264
- Side reinforced panel only in combination with side shelf, for against the wall installations, right PNC 913266
- Filter W=800mm PNC 913665
- Stainless steel dividing panel, 800x800mm, (it should only be used between Electrolux Professional thermaline Modular 80 and thermaline C80) PNC 913669
- Electric mainswitch 63A 10mm² NM for modular H800 electric units (factory fitted) PNC 913677
- Stainless steel side panel, 800x800mm, flush-fitting (it should only be used against the wall, against a niche and in between Electrolux Professional thermaline and ProThermetic appliances and external appliances - provided that these have at least the same dimensions) PNC 913685

Front

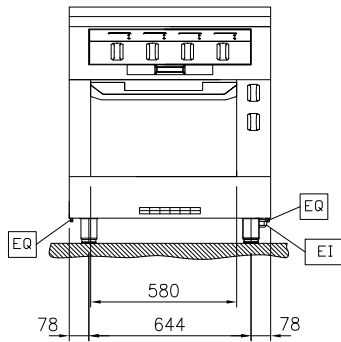

Side

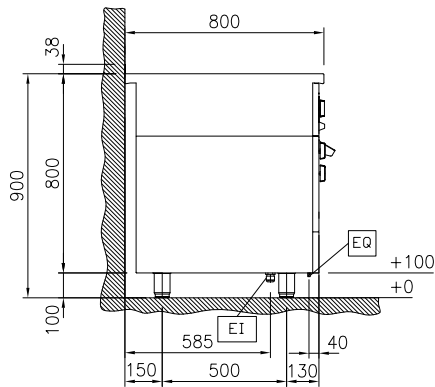

EI = Electrical inlet (power)
EQ = Equipotential screw

Top

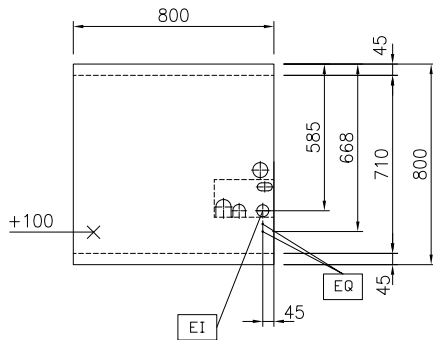

Electric

Supply voltage: 400 V/3N ph/50/60 Hz
Electrical power, max: 17.3 kW

Key Information:

Working Temperature MIN: 100 °C
Working Temperature MAX: 450 °C
External dimensions, Width: 800 mm
External dimensions, Depth: 800 mm
External dimensions, Height: 800 mm
Net weight: 208 kg
Configuration: On Oven; One-Side Operated
Front Plates Power: 3 - 3 kW
Back Plates Power: 3 - 3 kW
Solid top usable surface (width): 670 mm
Solid top usable surface (depth): 650 mm

Sustainability

Current consumption: 31.7 Amps